

Polymer Transistors for Printable Circuits

**Arash Takshi, John D.W. Madden, Alexandros Dimopoulos
and Milad Mohammadi**

Contacts:

John: JMadden@ece.ubc.ca

Arash: Arasht@ece.ubc.ca

Molecular Mechatronics Lab

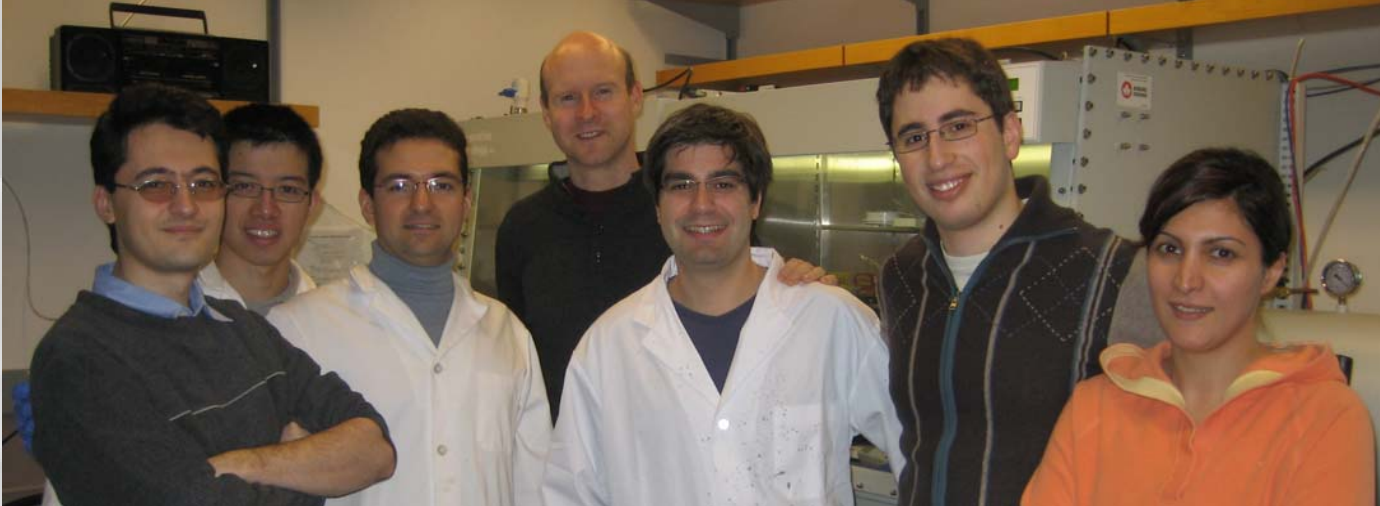

John D. Madden

Ph.D. Arash Takshi, Eddie Fok, Tissa Mirfakhrai, Tina Shoa

M.A.Sc. Alex Dimopoulos, Paul Perreira, Joanna Lam

B.A.Sc. Paul Cheng, Niloofar Fekri, Erik Miebling, Duncan Irwin, Rahul Krishna Prasad, Milad Mohammadi



**University of
British Columbia**

ICICS



MicroNano Technology Group, UBC (www.mina.ubc.ca)

- 13 faculty:
 - Carbon nanotube electronics, devices & modeling;
 - Si nanowires; Microfluidics; Implantable microdevices; Micro electrical discharge machining; photonics on chip; Cell sorting; Directed cell growth
 - MicroSensors/Energy harvesting; Modeling Na/K channels.

System-on-chip group

AMPEL CENTRAL FACILITIES:

used by AMPEL/other UBC Research Groups/Industry

- Micro/Nanofabrication facility
- Interface Analysis and Reactivity Laboratory
- Density Functional Theory and Materials Modeling
- Epitaxial Thin Film Growth and Surface Spectroscopy
- Materials Thermo-Mechanical Simulation/Characterization
- High Head Area
- Student Machine Shops – includes a small tools facility with ICICS





Organic Electronics

Some Background

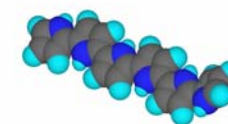

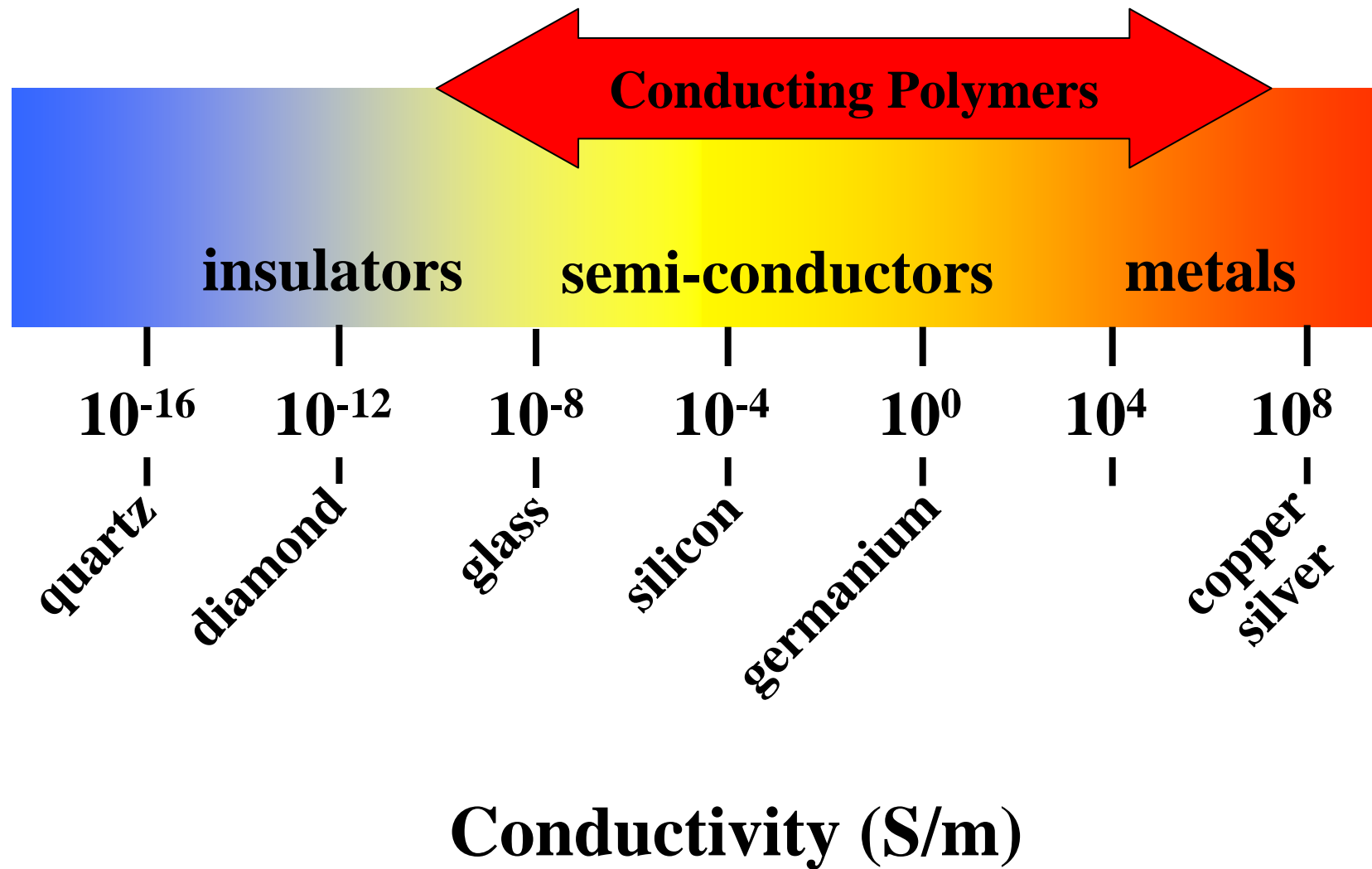

Organic Semiconductors

- Small Organic Molecules

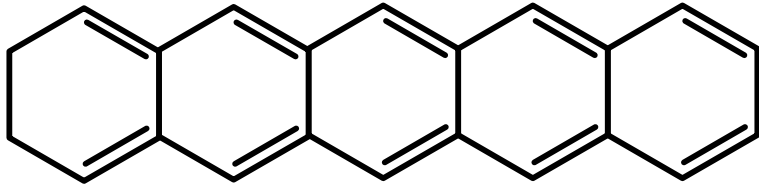

(a)

Pentacene

- Conducting Polymers

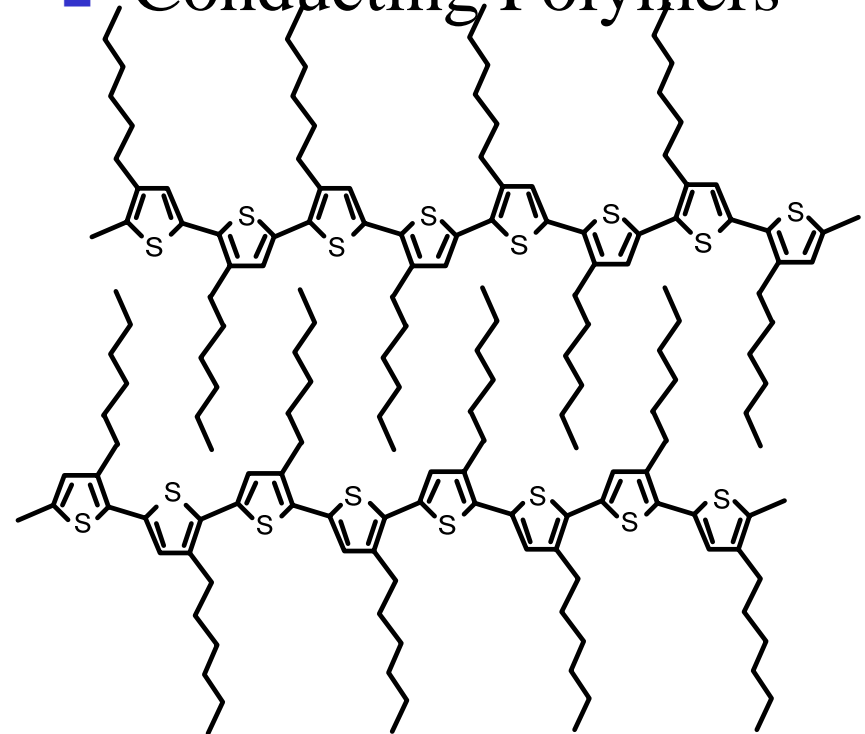

(b)

Poly-3-hexylthiophene
(Regioregular)

IBM

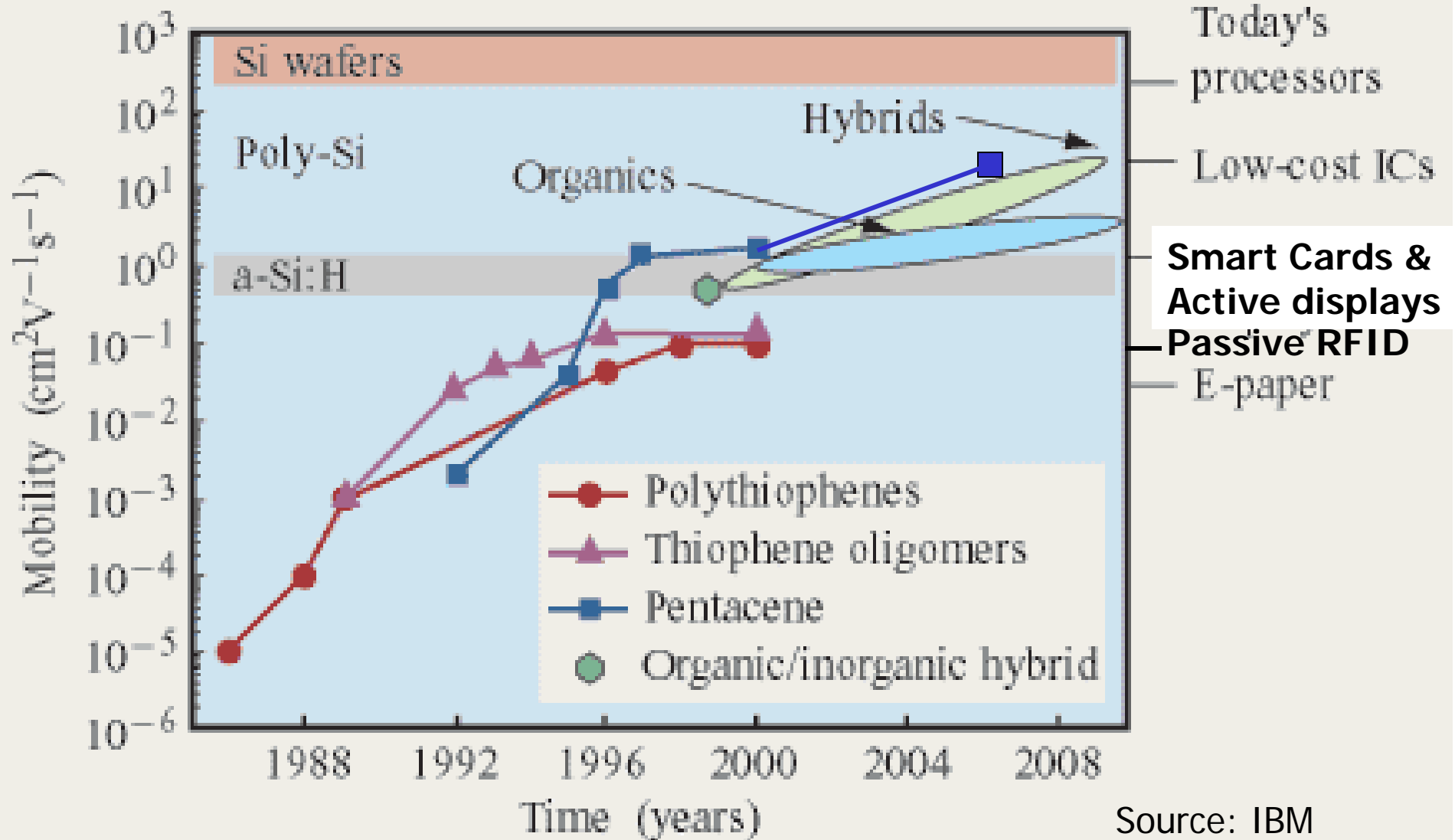

Source: IBM

Background: Polymer Semiconductors

- **Energy structure**
 - Narrow (no) bands
 - Localized states

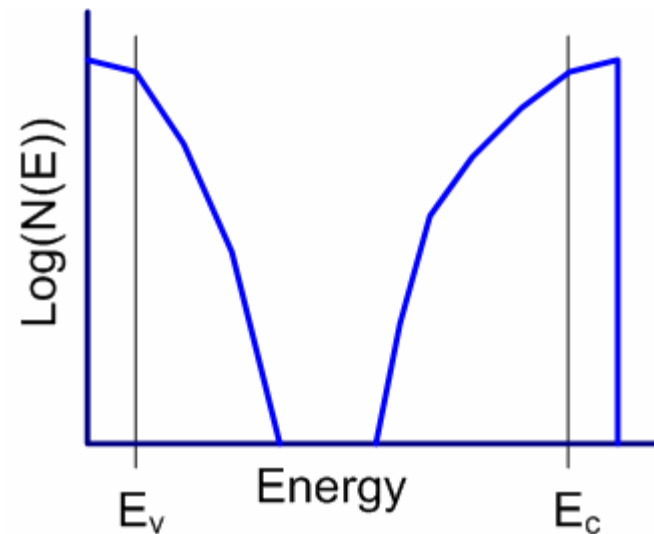

Background

- Doped semiconductor
- Depletion
 - (lower mobility)
- Accumulation
 - (higher mobility)

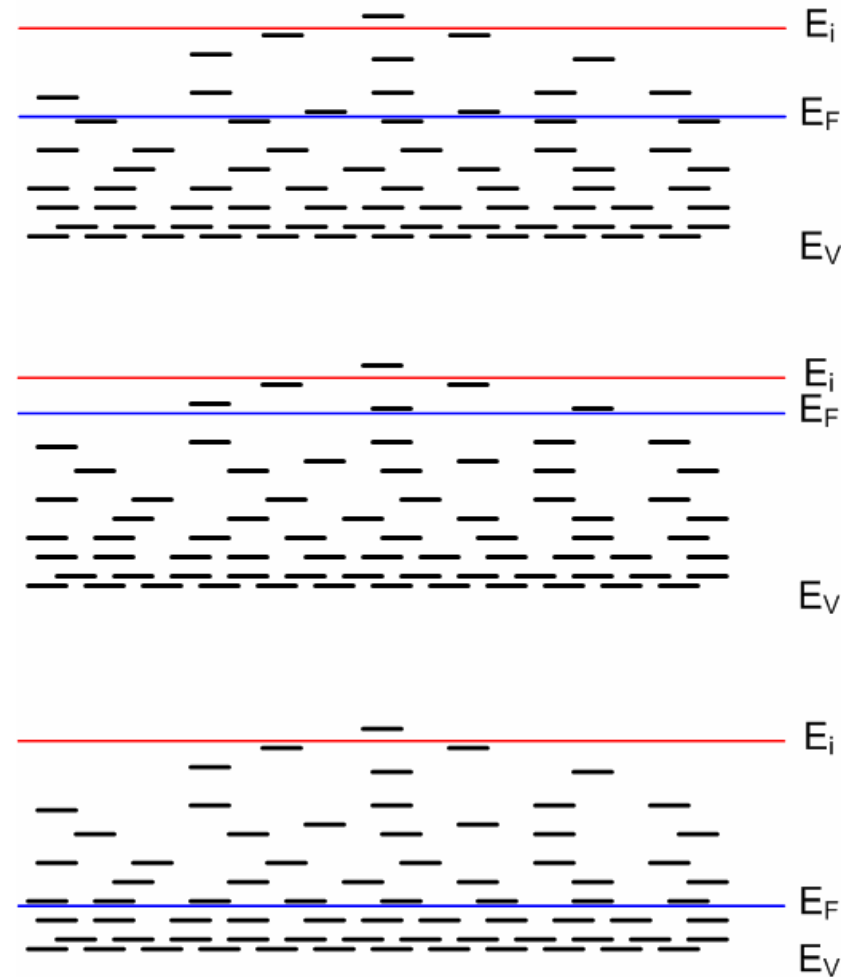

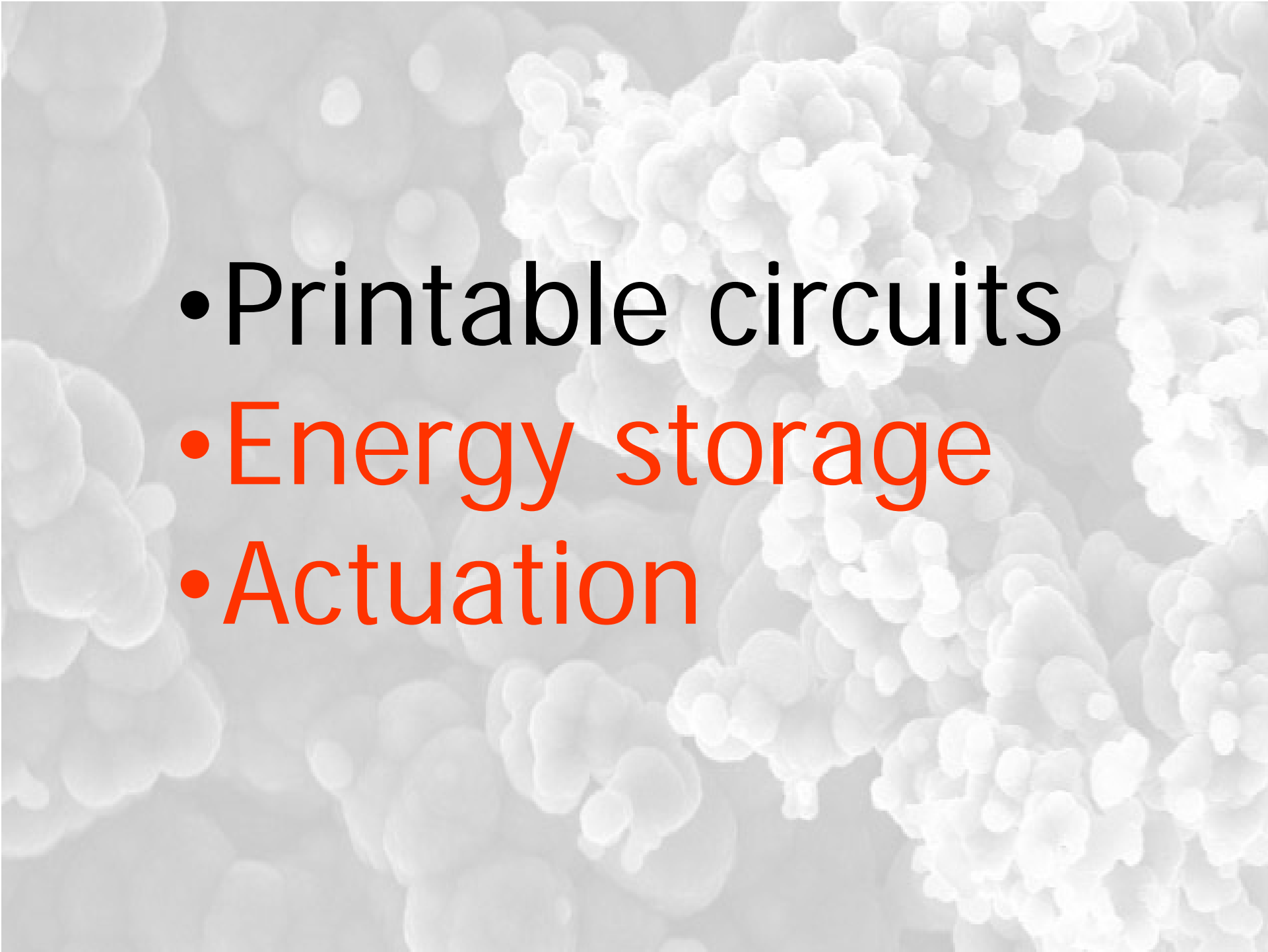

**Why use these
inferior materials?**

- 
- Printable circuits
 - Energy storage
 - Actuation



Organic Semiconductor Properties

- Compliant (Flexible)
- **Simple and inexpensive process of fabrication**
- Tunable electrical and chemical properties (e.g. bandgap/colour)
- Heterojunction devices
- 3D fabrication
- Biocompatibility



Ubiquitous Electronics

- Printed on packaging, textiles, paper...
- Applications include:
 - RFID tags
 - Distributed sensors
 - In package sensors
 - Flexible Displays
- Cost is critical, performance is not.

**Spin off Company from
Cambridge University.**

**\$30M from international
investors.**

Active Matrix Displays.

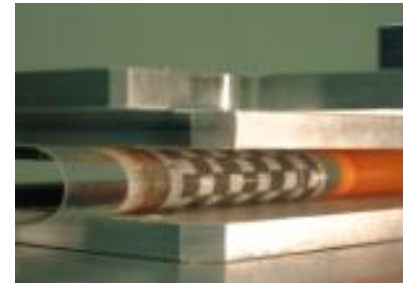

PolyIC

- started in November 2003
- PolyIC is headquartered in Erlangen, at the Siemens Research Centre.
- PolyIC is developing and evaluating RFID tags with Siemens, Lufthansa and others.

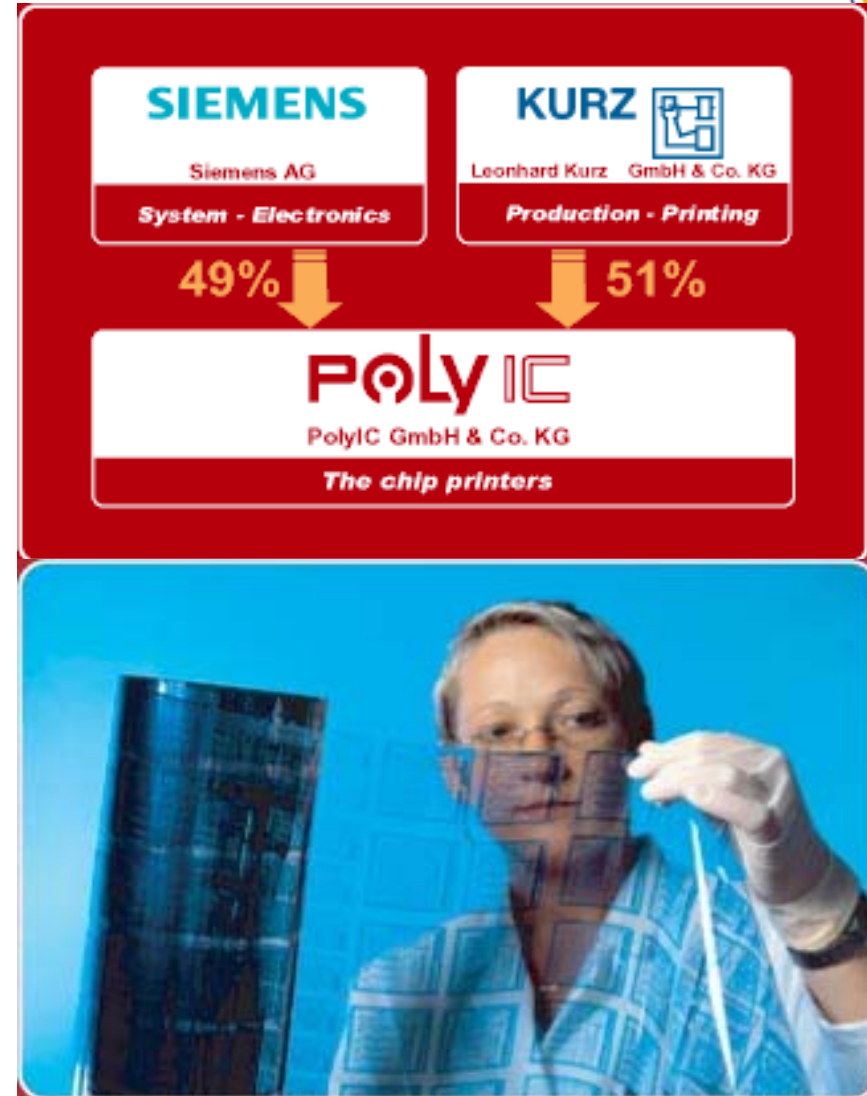

Sony



- 2.5", 120×169 pixels (RGB)
- Organic TFT
- 100 cd/m² brightness,
- 1,000:1 contrast ratio
- 0.3 mm thick
- (see YouTube video)





Printable Organic Semiconductor Challenges

- **Poor performance**
- **High Voltage Operation**

- Mobility
- Stability

Similarities with amorphous Si.



Printing challenge

- Thick layers, not ideal for transistor geometries
(high voltages, low on/off ratios)
- Solution:
 - 1) Use MESFET geometry to lower voltage.
 - 2) Use second gate to improve performance.

How does an OFET work?

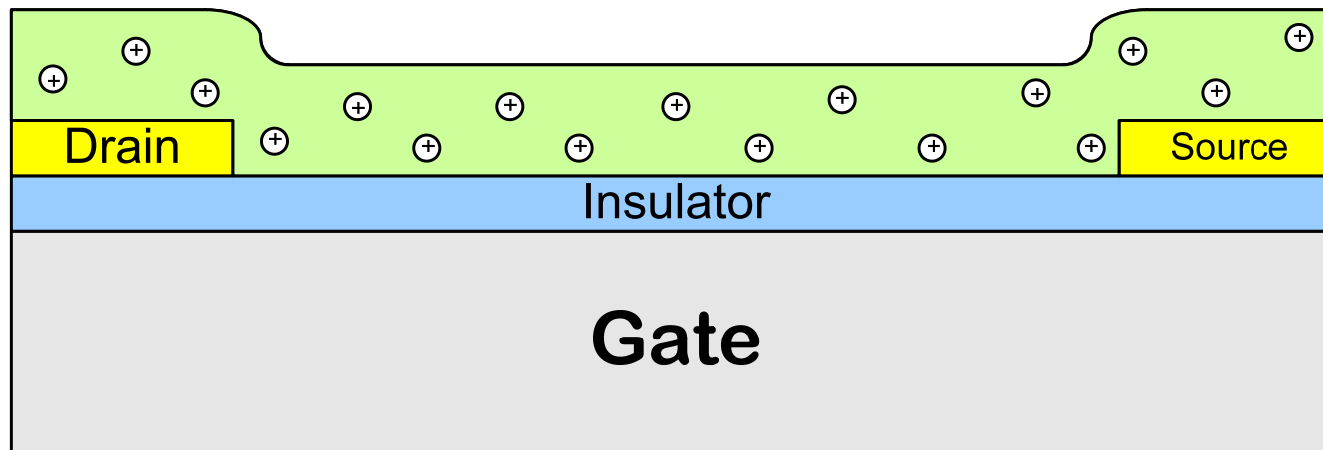

Accumulation Mode: On

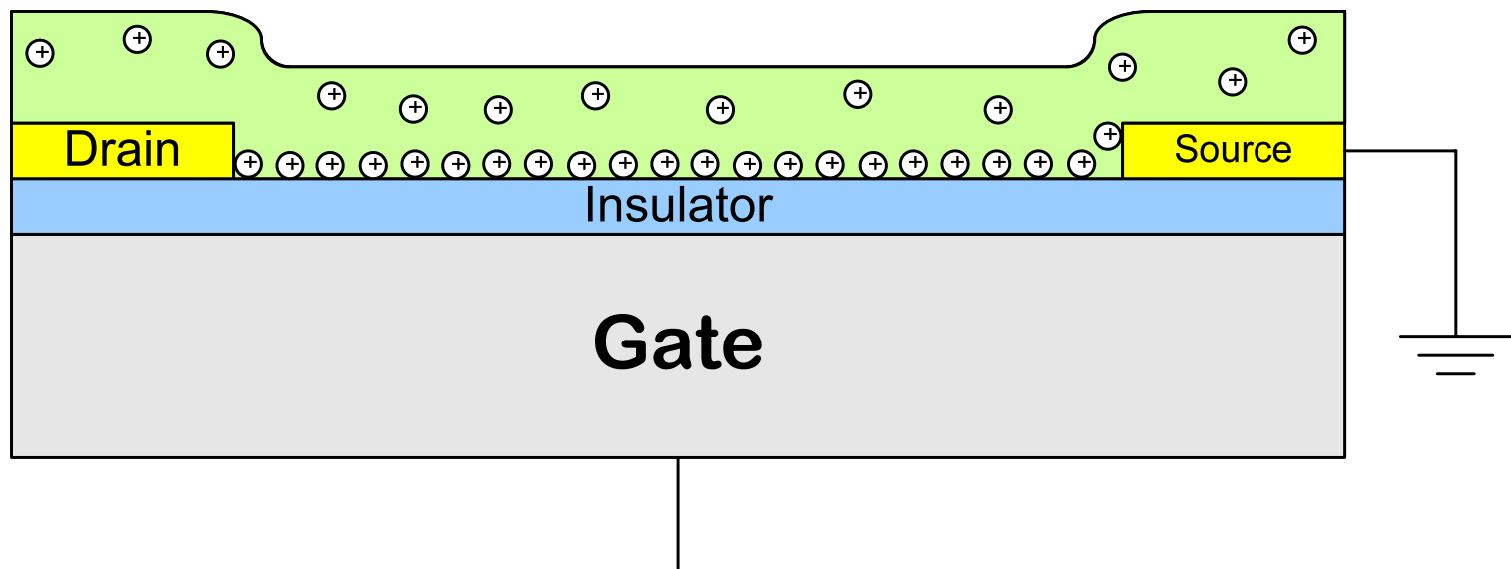

$$V_{GS} < 0$$

Depletion Mode: Off

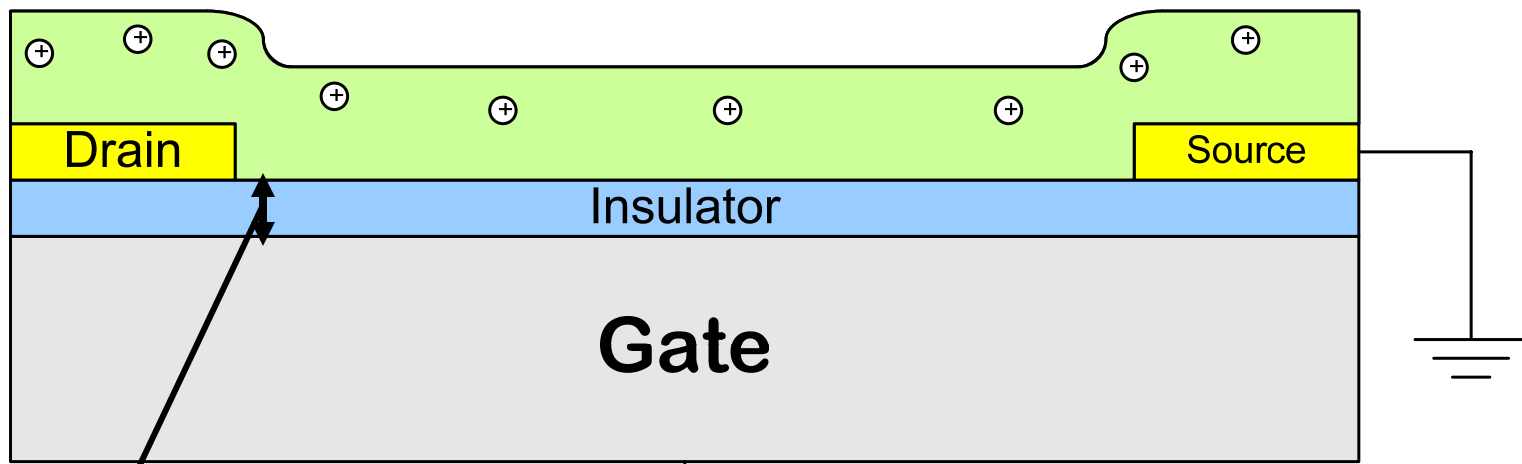

Thicker layer – higher voltage

$$V_{GS} > 0$$

Depletion Mode: Off

Thicker layer – larger leakage

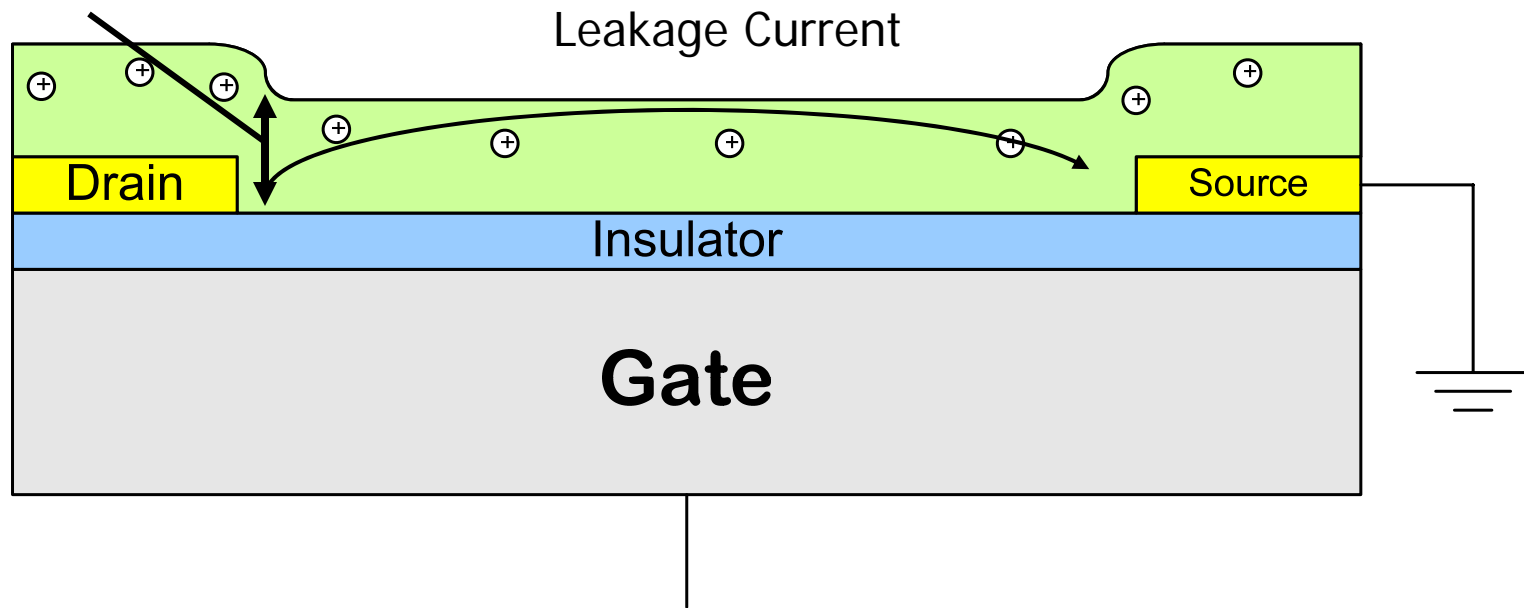

$$V_{GS} > 0$$

Organic Field Effect Transistor (OFET)

Characteristics

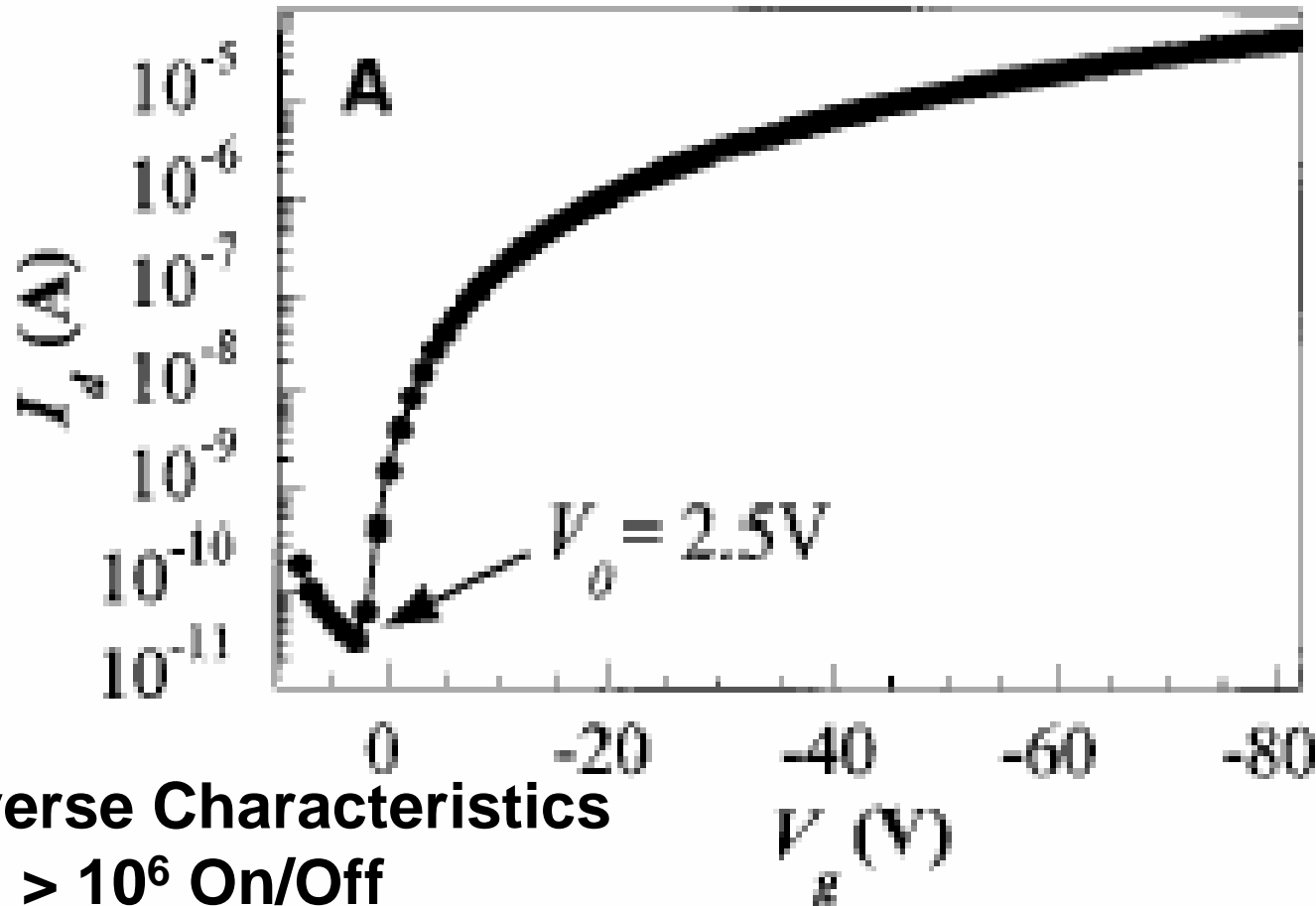

Transverse Characteristics
> 10^6 On/Off

Science. 280, 1998, pp. 1741-1744.
rr-P3HT, best to date.

Organic Field Effect Transistor (OFET)

Characteristics

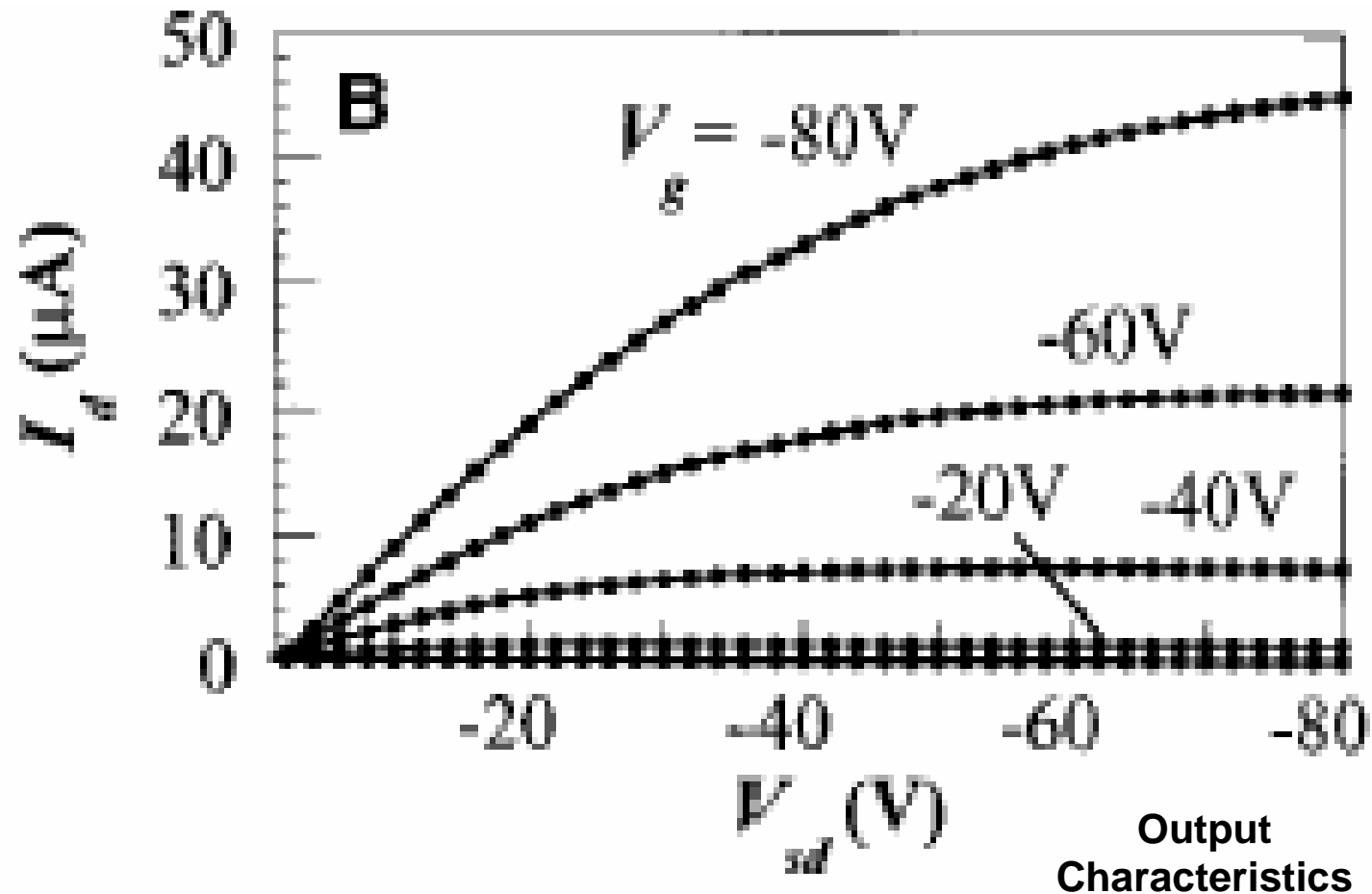

Science. 280, 1998, pp. 1741-1744.

rr-P3HT, best to date.



Challenges

- High Voltage
- Poor On/Off in printable devices

A grayscale scanning electron micrograph (SEM) showing a dense field of spherical, textured particles. The particles vary in size and are clustered together, creating a complex, porous-looking structure. The lighting highlights the surface texture of the spheres.

Organic MESFET

How does a O-MESFET work?

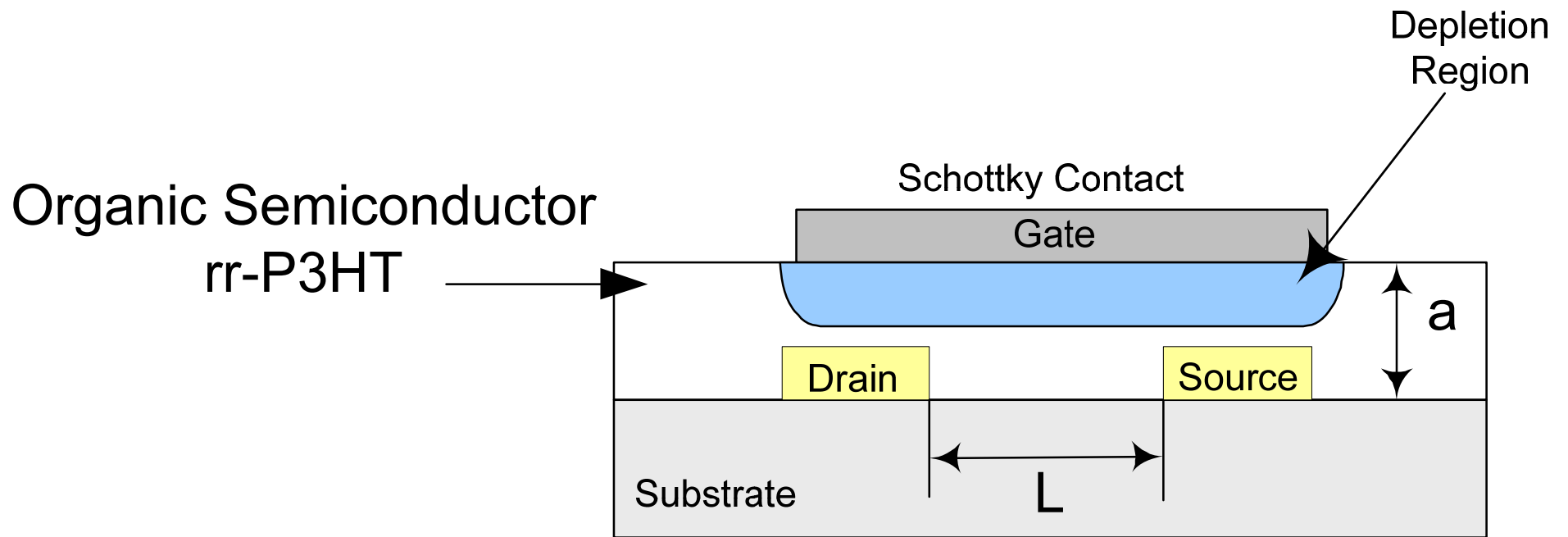

OMESFET



- 400 nm
- $\mu = 8 \times 10^{-6} \text{ cm}^2/\text{Vs}$
- $V_t = 3.5 \text{ V}$

Simulation

- $I_{\text{on}}/I_{\text{off}} = 10^4$ in 5 V
- $S = 180 \text{ mV/decade}$

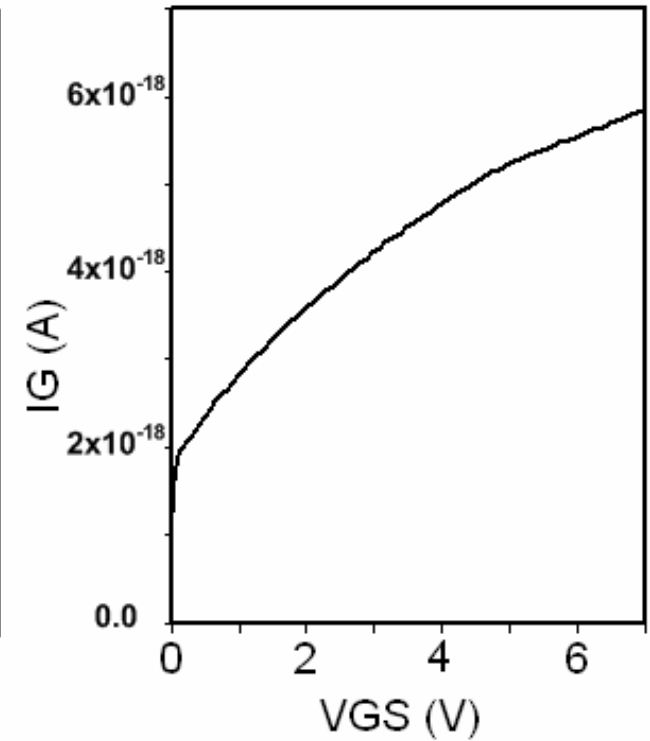
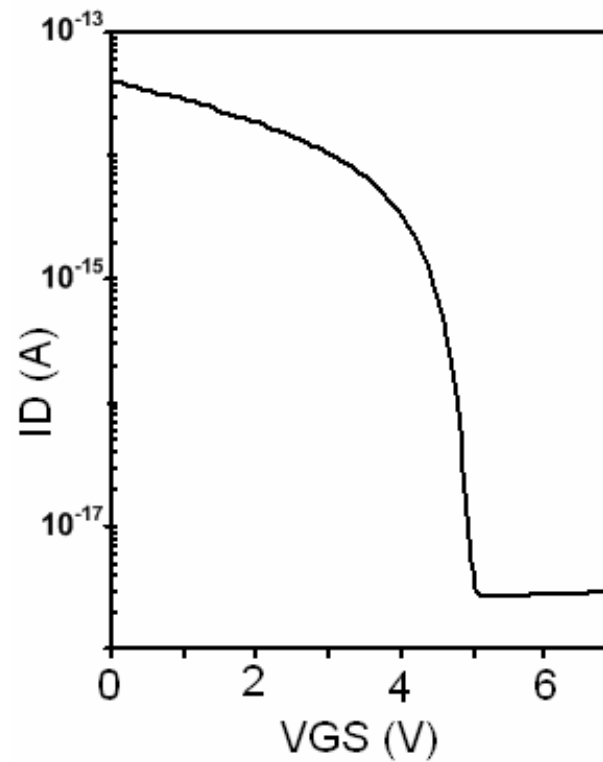
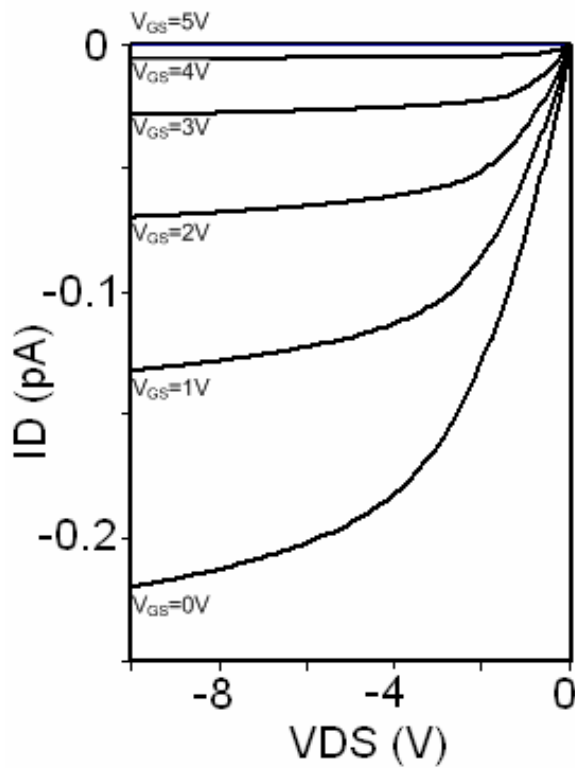

OMESFET



- 200 nm dip cast
- $\mu = 1.6 \times 10^{-4} \text{ cm}^2/\text{Vs}$
- $V_t = +3.5 \text{ V}$

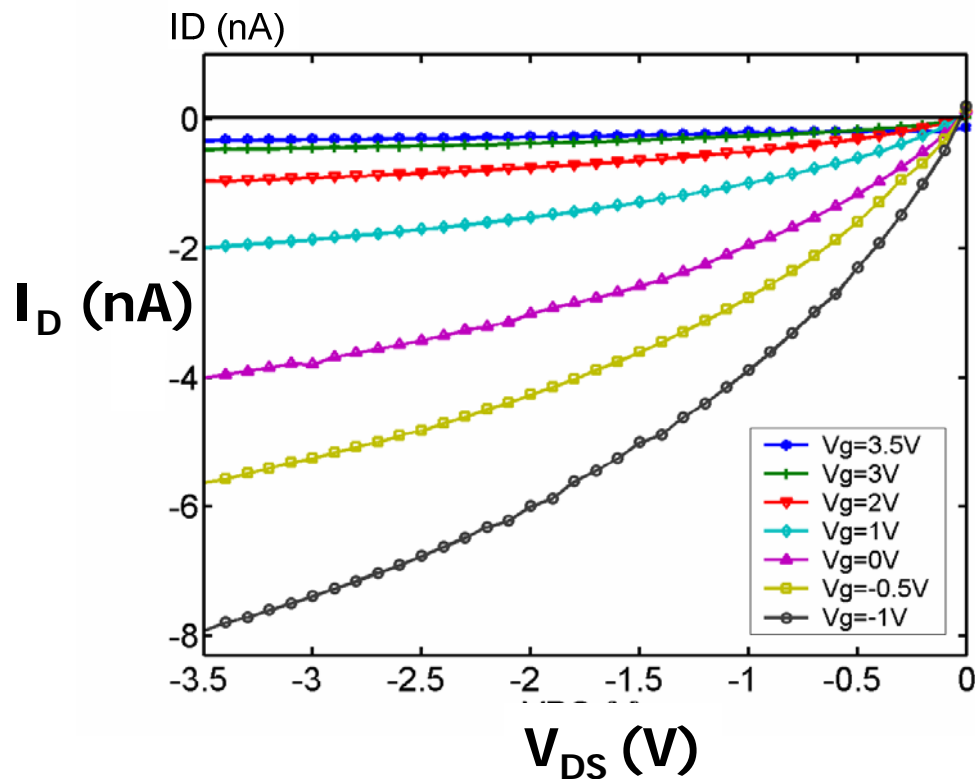

Experiments

- $I_{\text{on}}/I_{\text{off}} = 24.6$ in 4.5 V
- $S = 3.2 \text{ V/decade}$
- Depletion and enhancement modes

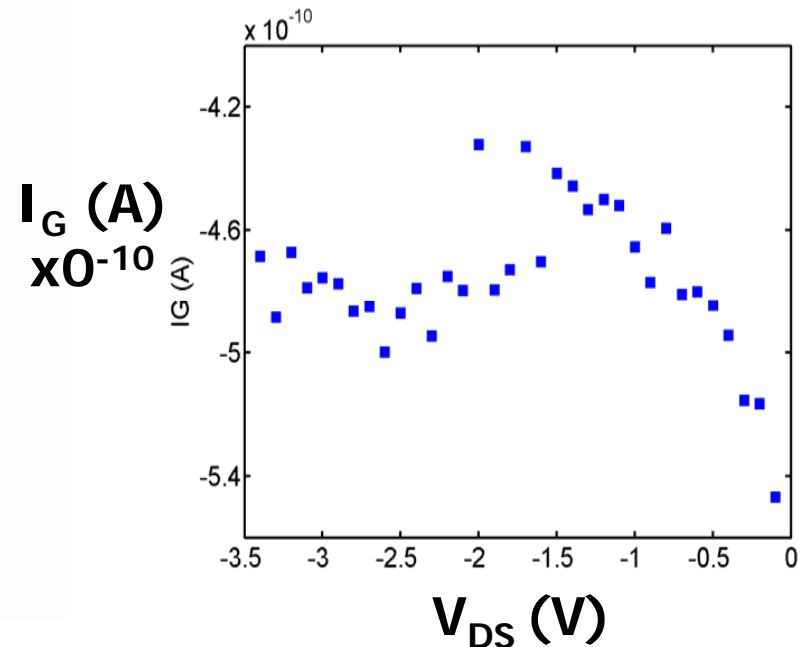

How to improve the OMESFET?



Suggestion

- Reduce the gate current
- Use a thicker semiconductor layer
- Higher doping density
- Lower workfunction metal
- Replace metals with organics

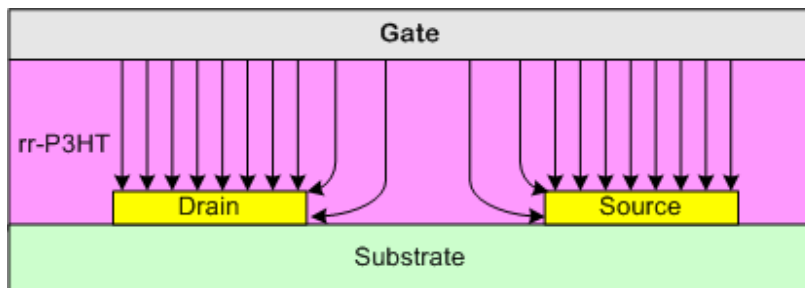

(a)

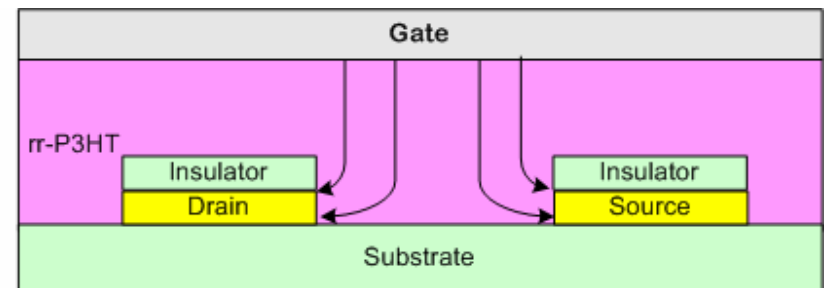

(b)



OFET vs OMESFET

- OMESFETs exhibit low voltage operation
 - Lower dissipation
 - Battery operation
 - Easier for passive RFID
- But current and mobility are lower in OMESFETs.



Improving Printed OFETs

Dual Gate Structure

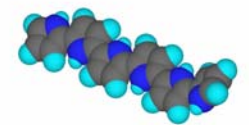

Thick film OFET



Modeling

- Effect of the thickness:
 - Shift in V_t

$$V_{Tapp} = \left(V_T - \frac{\sigma_{blk} t_s}{\mu_f C_i} \right)$$

- Change in R_{out}
- Change in I_{on}/I_{off}

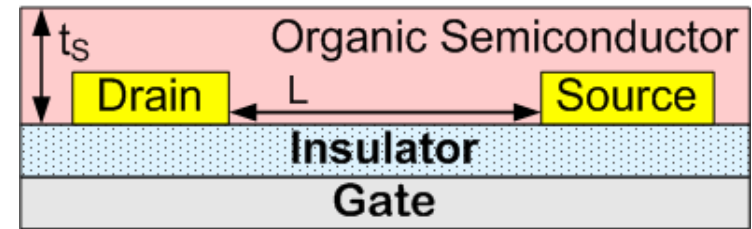

(a)

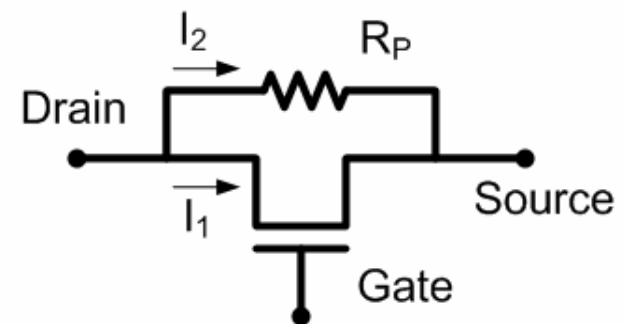

(b)

Dual gate organic transistor



Structure

- A solution for a thick film OFET when a printing method is applied
- Combination of an OFET and an OMESFET

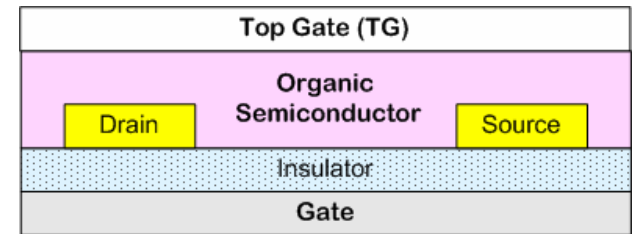

(a)

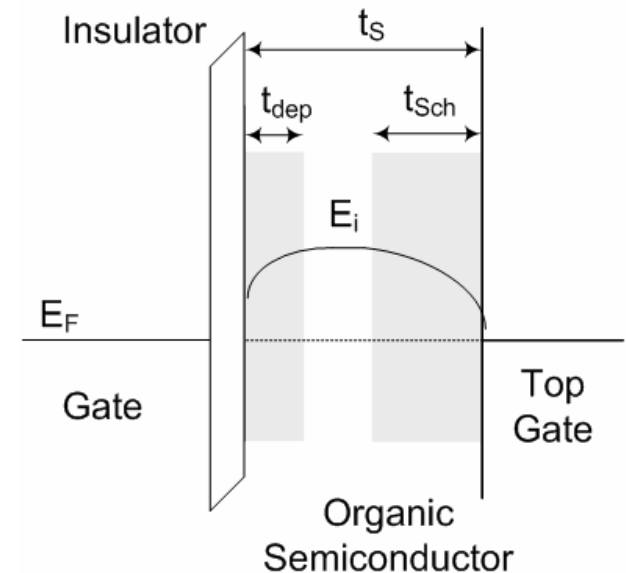

(b)

Dual gate organic transistor



Experiments

■ OFET

- 350 nm dip cast
- $\mu = 3.24 \times 10^{-4} \text{ cm}^2/\text{Vs}$
- $V_t = +12.5 \text{ V}$
- $I_{\text{on}}/I_{\text{off}} \approx 5$ in 20 V

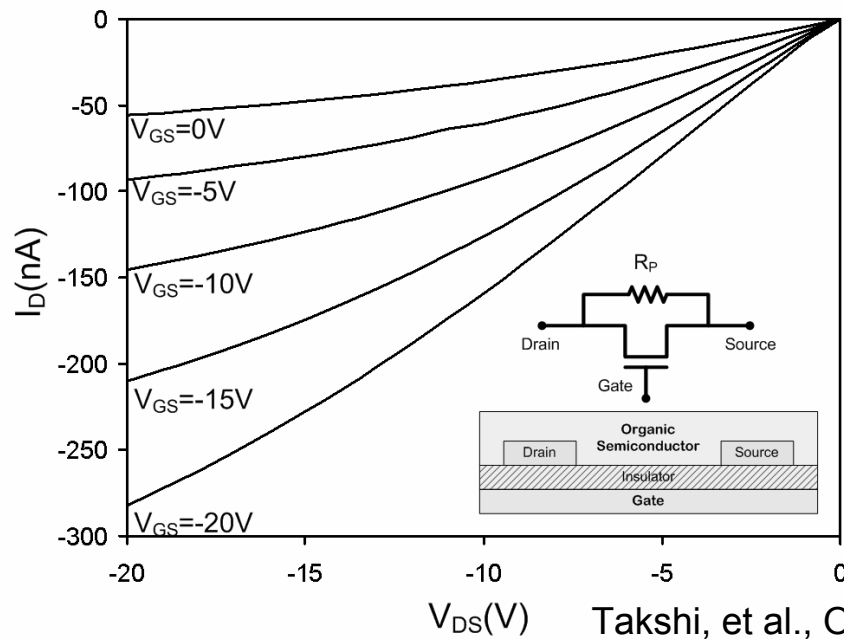

■ Dual gate (floating gate)

- 120 nm Al
- 350 nm dip cast
- $V_t = -0.01 \text{ V}$
- $I_{\text{on}}/I_{\text{off}} \approx 20.5$ in 20 V

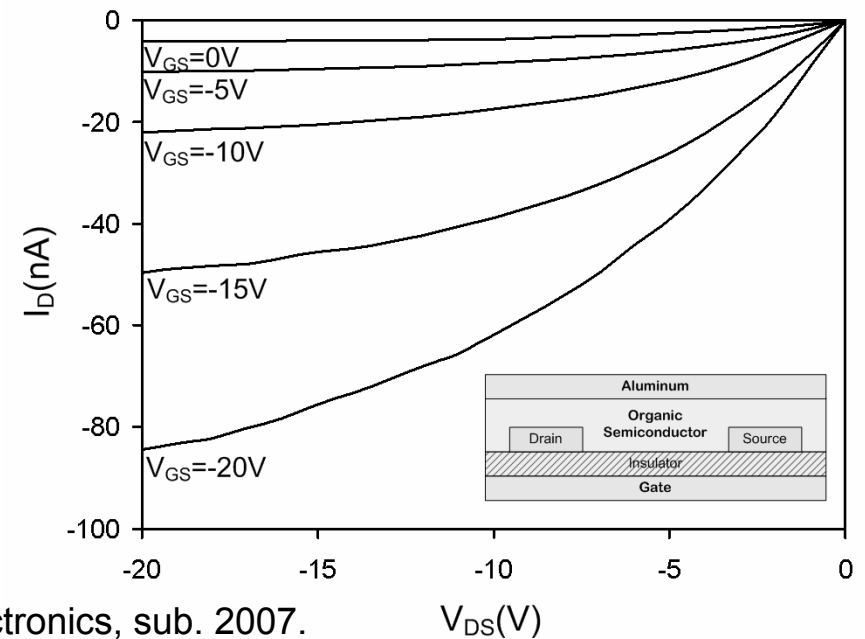



Next Steps

- Increase On/Off ratio
- Demonstrate AC characteristics
- Demonstrate printing
- Applications
 - Passive RFID
 - E-paper